

File Name	VT100-L User Manual	Ver.	1.0
Update	2022-02-28	Page	1 of 23

GPS Vehicle Tracker VT100-L User Manual V1.0

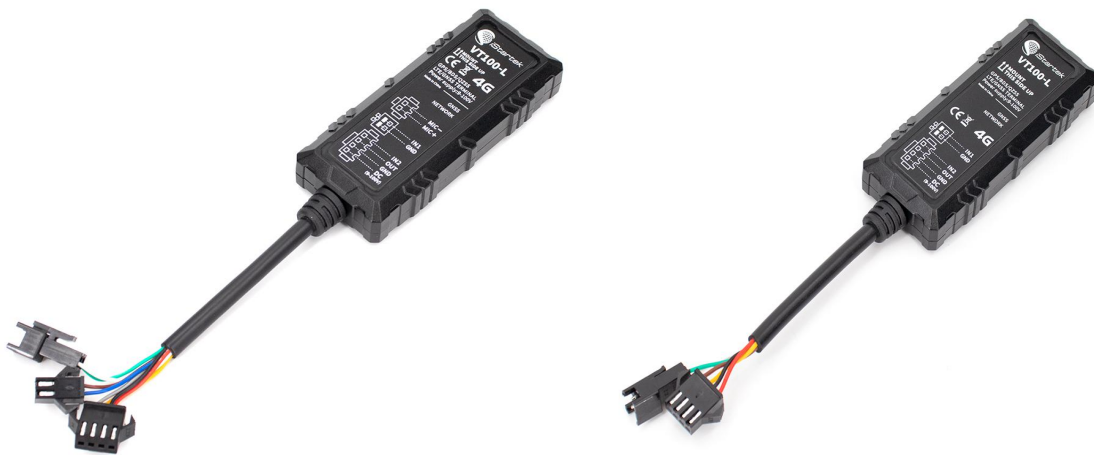

File Name	VT100-L User Manual	Ver.	1.0
Update	2022-02-28	Page	2 of 23

Content

1. Product Description	3
2. Product Function	3
3. Product Specification	4
4. Products and accessories	6
5.1 Standard accessories	6
5.2 Optional accessories	6
5. Product Appearance	7
6. Product Operation	9
7.1 Recharge	9
7.2 Install SIM card	9
7.3 Turn on Device	9
7.4 Track by SMS	9
7.5 Parameter configuration	10
7.6 Track by GPS Tracking Platform	10
8. Product Installation	11
8.1 Power Cable Function Introduction	11
8.2 Device Installation	12
8.3 Analog Input Installation	13
8.4 Ultrasonic Fuel Sensor Installation	16
8.5 Speed Limiter Installation	21

File Name	VT100-L User Manual	Ver.	1.0
Update	2022-02-28	Page	3 of 23

This manual cannot be copied for any purpose, disseminated in any way without the written authorization of Pictor Telematics shall not be liable for direct, indirect or all losses (including but not limited to economic losses, personal injuries, property and assets) caused by the use or inappropriate use of the product or documents.

2. Product Description

VT100-L is a 4G based vehicle GPS Tracker with built-in high-precision, GPS+BDS dual-mode positioning module; It integrates functions of driving behavior monitoring, remote fuel cut, low power alarm, external power disconnect alarm, various abnormal alarms, electronic geo-fences etc., and uploads information to the platform to create comprehensive supervision and security for vehicle driving. By its ultra mini size, it is easier to install and hide, which is suitable for the automotive risk control industry, vehicle supervision, anti-theft and shared travel industries.

VT100-L has a built-in 16Mb Flash memory. When the device enters a place without network, it will automatically save the historical positioning data. When the network returns to normal, it will automatically resend the historical positioning data to the tracking platform.

3. Product Function

- ✧ GPS+BDS dual mode positioning
- ✧ Real-time tracking
- ✧ Track by time interval
- ✧ Track by distance
- ✧ SMS Alarm
- ✧ SOS Alarm
- ✧ External power disconnection alarm
- ✧ Low battery alarm
- ✧ Engine and door status change alarm
- ✧ Support dual servers
- ✧ Geo-fence alarm
- ✧ Speeding alarm
- ✧ GPS signal loss alarm
- ✧ Harsh acceleration alarm
- ✧ Harsh deceleration alarm
- ✧ Harsh turning alarm

File Name	VT100-L User Manual	Ver.	1.0
Update	2022-02-28	Page	4 of 23

- ✧ Impact alarm
- ✧ Vibration (towing) alarm
- ✧ Idling alarm
- ✧ Fatigue driving alarm
- ✧ Mileage report
- ✧ Heading change report
- ✧ 16 Mb Flash
- ✧ FOTA upgrade
- ✧ Set ACC ON, ACC OFF time interval
- ✧ Remote control fuel/electricity
- ✧ Buzzer alarm (optional)
- ✧ Fuel sensor (optional)
- ✧ Fuel theft alarm (optional)
- ✧ Low fuel alarm (optional)

4. Product Specification

Item	Specification
Size	80*34*15mm
Weight	Around 48g
Input voltage	DC 9 - 100V/1.5A
Waterproof level	IP66
Inbuilt Battery	55mAh
MCU	Cortex-M4, AT32F415CBT7
Average standby power consumption	51mA/h
Operating temperature	-20~80°C
Battery operating hours	30min
LTE/WCDMA/GSM Bands	<p>Cat-1(A7670) , 4G LTE, SIMCOM</p> <p>VT100-L CN: LTE-FDD: B1/B3/B5/B8 LTE-TDD: B34/B38/B39/B40/B41 GSM: 900/1800MHz Standard version I/O: DCIN+GND+OUT1+IN2+SOS+MIC (8-wire)</p> <p>VT100-L EU: LTE-FDD: B1/B3/B5/B7/B8/B20 GSM: 900/1800MHz Standard version I/O: DCIN+GND+OUT1+IN2+SOS+MIC (8-wire)</p> <p>VT100-L SA: LTE-FDD: B1/B2/B3/B4/B5/B7/B8/B28/B66</p>

File Name	VT100-L User Manual	Ver.	1.0
Update	2022-02-28	Page	5 of 23

	<p>GSM: 850/900/1800/1900MHz Standard version I/O: DCIN+GND+OUT1+IN2+SOS+MIC (8-wire)</p> <p>Cat-M/Cat-NB/GSM(SIM7070G), SIMCOM VT100-L MNG: Cat-M: B1/B2/B3/B4/B5/B8/B12/B13/B14/B18/B19/B20/B25/B26/B27/B28/B66/B85 Cat-NB: B1/B2/B3/B4/B5/B8/B12/B13/B18/B19/B20/B25/B26/B28/ B66/B71/B85 GSM: 850/900/1800/1900MHz Standard version I/O: DCIN+GND+OUT1+IN2+SOS (6-wire)</p> <p>Cat-1(SIM7500) , 4G LTE, SIMCOM VT100-L NA-7500: LTE-FDD: B2/B4/B12 WCDMA: B2/B5 Standard version I/O: DCIN+GND+OUT1+IN2+SOS (6-wire)</p> <p>VT100-L SA-7500: LTE-FDD: B1/B3/B5/B7/B8/B28 WCDMA: B1/B5 Standard version I/O: DCIN+GND+OUT1+IN2+SOS (6-wire)</p> <p>VT100-L GL LTE-FDD B1/B2/B3/B4/B5/B8/B12/B13/B14/B17/B18/B19/ B20/B25/B26/B27/B28/B31/B39/B66/B71/B85 GSM/GPRS/EDGE 900/1800MHz</p>
GPS Module	L76K (GPS+BDS) dual mode positioning
GPS Sensitivity	-165dB
Positioning accuracy	2.5 meters
LED Indicator	2 LED lights indicate GPS/GSM status. 1 each of blue and green LED indicators, built-in indicators, visible from the outside through light
GSM antenna	Inbuilt FPC
GPS antenna	Built-in ceramic antenna (25 X 25 X 4mm)
Flash	16M bit
Sensor	3D accelerometer
Switch	Plug and unplug the SIM card to automatically turn on and turn off the device
SIM Card	Nano SIM card
I/O	2 Digital inputs (Can be configured by software for high and low level trigger, Analog input. IN2 is set to ACC detection by default) 1 Output 1 Micro USB

File Name	VT100-L User Manual	Ver.	1.0
Update	2022-02-28	Page	6 of 23

	<p>1 Microphone (Only available for VT100-L LCN/LEU/LSA version)</p> <p>1 RS32/TTL (Customizable)</p> <p>Customized version:</p> <p>DICIN+GND+OUT1+IN2+SOS+RS232 (Customizable, MOQ500pcs)</p> <p>DICIN+GND+OUT1+IN2+MIC+RS232 (Customizable, MOQ500pcs)</p> <p>DICIN+GND+OUT1+IN2+IN1+MIC+RS232 (Can only receive data) (Customizable, MOQ500pcs)</p>
--	--

5. Products and accessories

5.1 Standard accessories

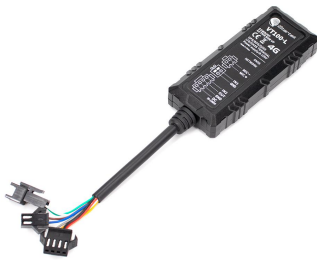

Main Unit with 8 Wires



Main Unit with 6 Wires

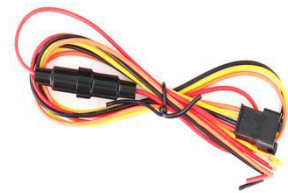

Power Cable

5.2 Optional accessories



12V/24V Relay



USB Cable



Buzzer



File Name	VT100-L User Manual	Ver.	1.0
Update	2022-02-28	Page	7 of 23

Microphone



Capacitive Fuel Sensor

SOS Button



Speed Limiter

Ultrasonic Fuel Sensor

5.3 Customizable accessories



RFID Reader



RFID Tag



OBD Decoder



Magnetic Card Reader

6. Product Appearance

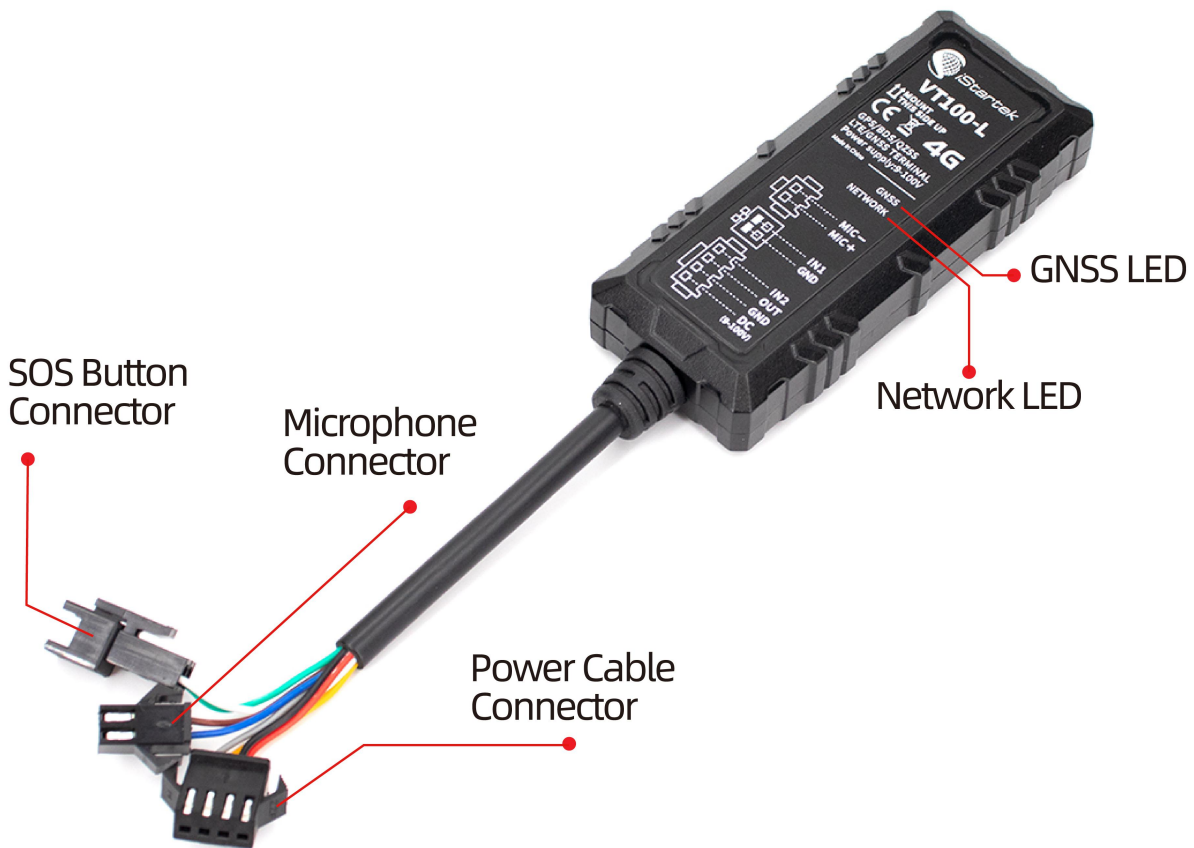

Front view of 8-wire device

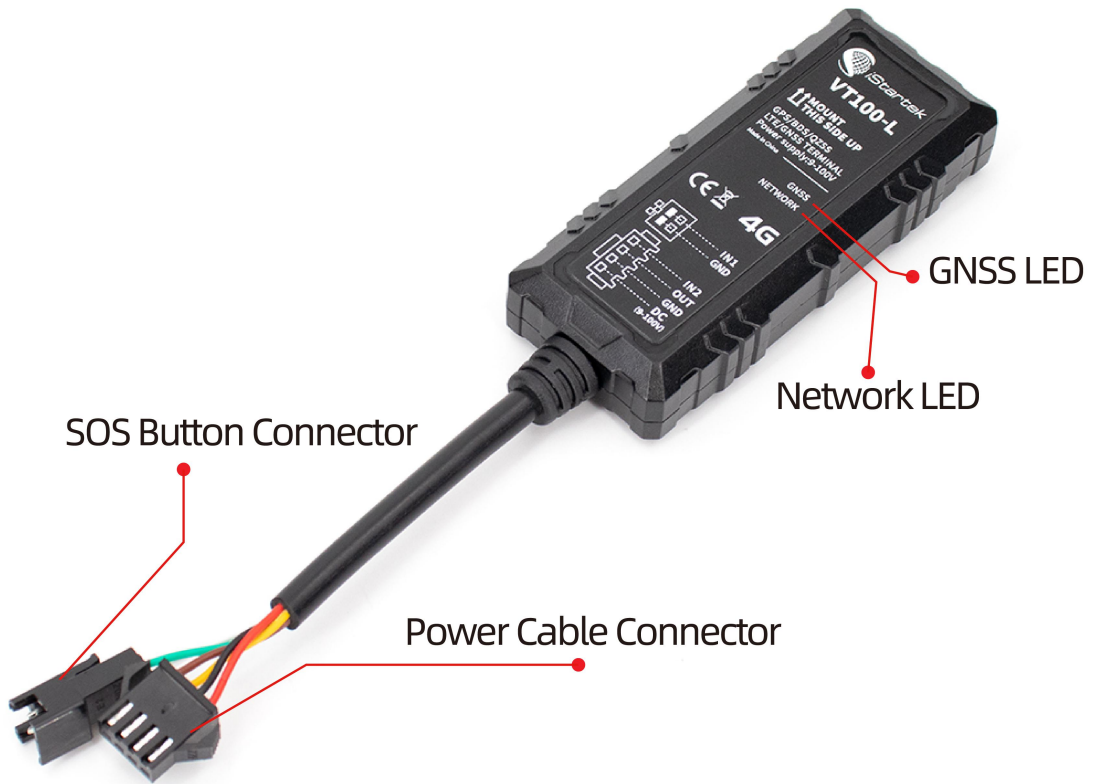

Front view of 6-wire device



Back image

7. Product Operation

7.1 Recharge

When using VT100-L for the first time, please connect the tracker's red wire (positive) and black (ground wire) to a 12V or 24V power supply and charge for at least 2 hours to ensure sufficient power. After configuration and testing are completed, install it on the vehicle.

7.2 Install SIM card

The device supports 4G SIM card;

Please make sure that the SIM card has sufficient balance, the GPRS function has been activated and the correct APN of the SIM card has been confirmed;

Please make sure that the PIN lock function of the SIM card is turned off;

If you need to use the function: Call to reply location, please make sure that the SIM card has the caller ID display function;

Please make sure the device is turned off before installing SIM.

- A. Remove the back cover;
- B. Install the SIM card in the correct direction.

7.3 Turn on Device

Switch ON device or connect to external power supply, VT100-L will start up and run.

LED lights indicate operating conditions:

GPS Indicator (Blue)	
OFF	Power OFF or in sleep mode
Flash (every 0.1 sec)	GPS module is starting or restarting
Fast Flash (0.1 sec ON, 2.9 sec OFF)	GPS signal received
Slow Flash (1sec ON, 2 Sec OFF)	No GPS signal
GSM Indicator (Green)	
ON	There is an incoming call or is in a call
OFF	Device is OFF or in sleep mode
Fast Flash (every 0.1 sec)	GSM module is starting or restarting
Fast Flash(0.1 sec ON, 2.9 sec OFF)	GSM signal received
Slow Flash (1sec ON, 2 Sec OFF)	No GSM signal

7.4 Track by SMS

Send SMS command to VT100-L:

0000,800

You will receive a text message with a link to Google maps. Click to open the link to display the current location on Google maps.

File Name	VT100-L User Manual	Ver.	1.0
Update	2022-02-28	Page	10 of 23

Please refer to "Pictor Telematics GPS Tracker Communication Protocol V1.4" for the description of SMS content and more SMS commands

7.5 Parameter configuration

Download and install the USB driver «PL2303_Prolific_Driver» .

After the device is turned on, connect the VT100-L to the computer via Pictor Telematics USB cable, run the "Pictor Telematics Parameter Editor_V1.6" configuration software and open the port to enter the parameter

For more parameter configuration, please refer to "Pictor Telematics Parameter Editor User Manual V1.5".

7.6 Track by GPS Tracking Platform

1. You can set the server IP, Port, and APN parameters through SMS commands **100, 102, and 109**, and you can also use the Pictor Telematics Parameter Editor software to configure related parameters.
2. Use SMS command 808 to query the parameters of commands 100, 101, 102, 105, 106, and 109. You can also use Pictor Telematics Parameter Editor to configure related parameters.

For more SMS command functions and parameter configuration, please refer to "Pictor Telematics GPS tracker Communication Protocol V1.3" and "Pictor Telematics Parameter Editor User Manual V1.5".

8. Product Installation

8.1 Power Cable Function Introduction

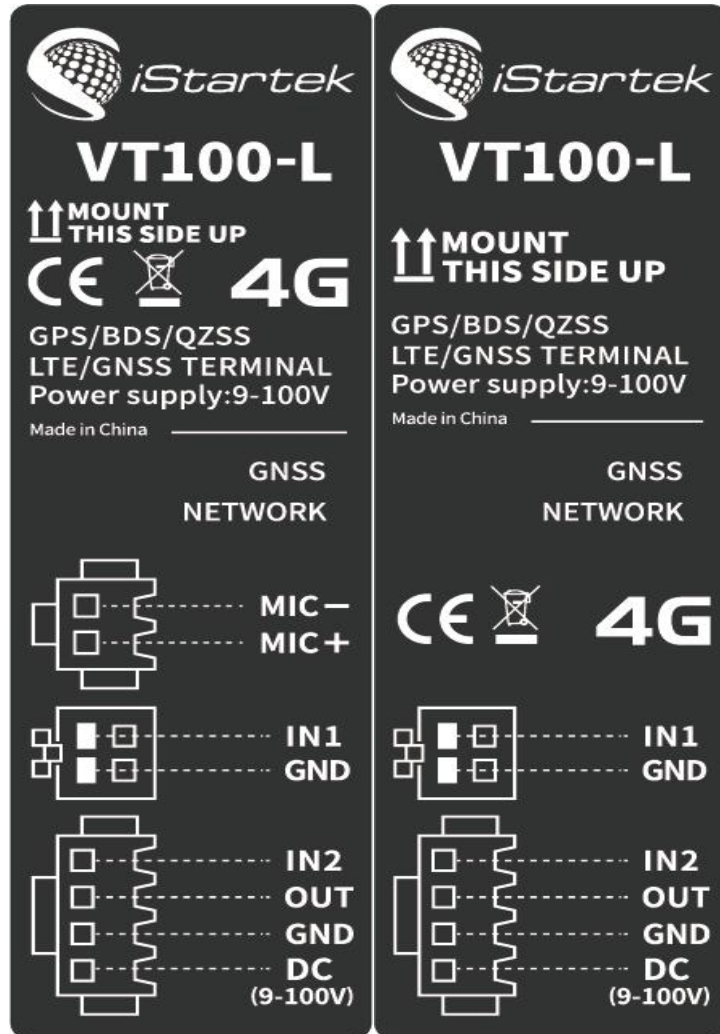

PIN	Color	Function
DC	Red	DC In (power input), connect to the positive pole of the car battery. Input voltage: 9V~100V
GND	Black	GND, connect to the negative pole of the car battery, or to the iron place on the car.
IN1	White	Digital input 1, default is negative trigger. Can config by software to set positive and negative trigger, AD1 input (0-6.6/13.2V) Connected to the SOS button defaultly
GND	Green	
IN2	Orange	Digital input 2, default is positive trigger. Can config by software to set positive and negative trigger, AD2 input (0-36V).

		Used for ACC detection.
OUT	Yellow	Open-drain output, drive capacity greater than 500MA, withstand voltage 100V; An external relay can be connected to remotely cut off the car's fuel/engine power supply, etc.
Mic+	Brown	External Microphone, used for listening.
Mic-	Blue	

8.2 Device Installation

①. 8-wire standard version of VT100-L wire connection:

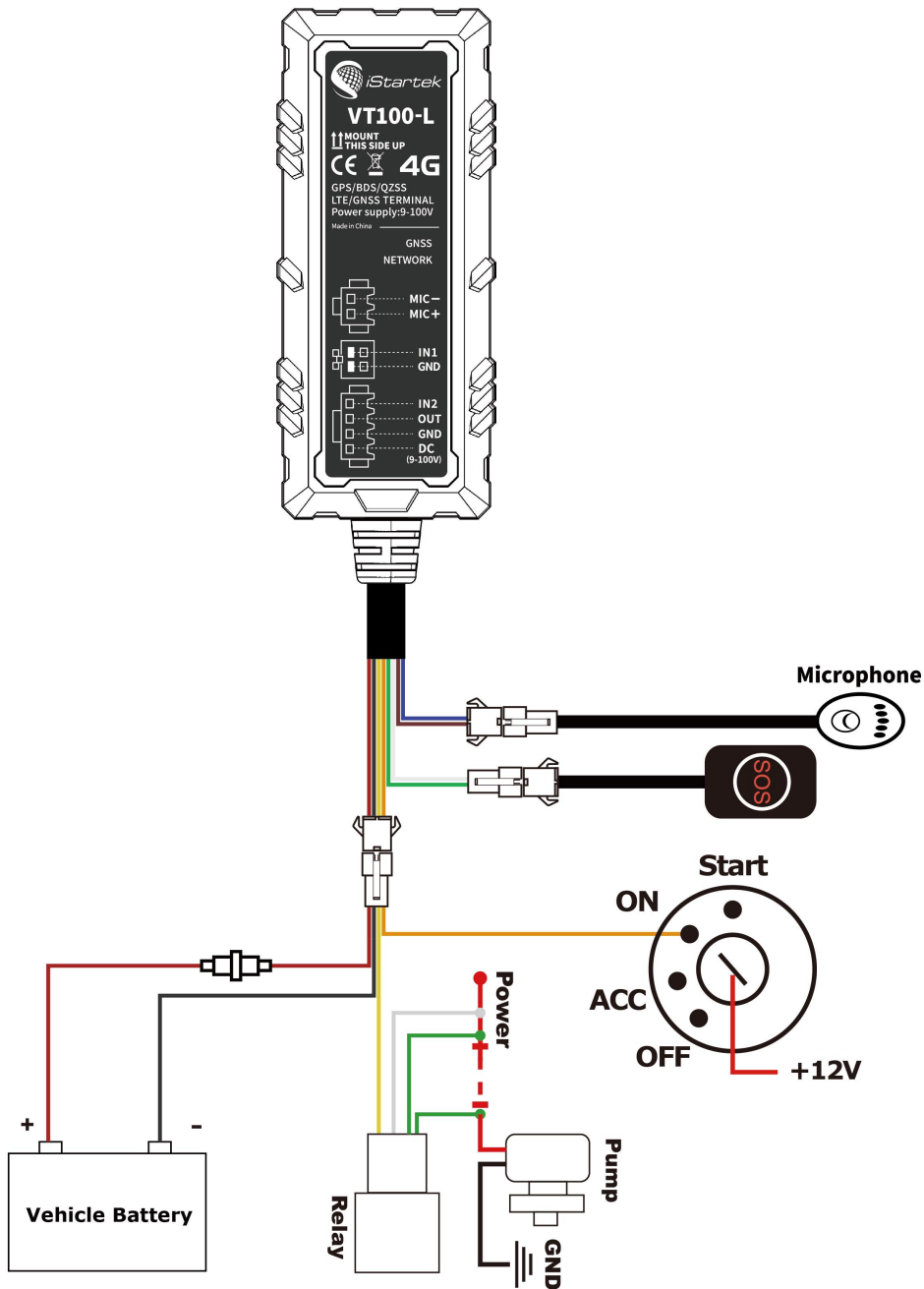

File Name	VT100-L User Manual	Ver.	1.0
Update	2022-02-28	Page	13 of 23

②. 6-wire standard version of VT100-L wire connection:

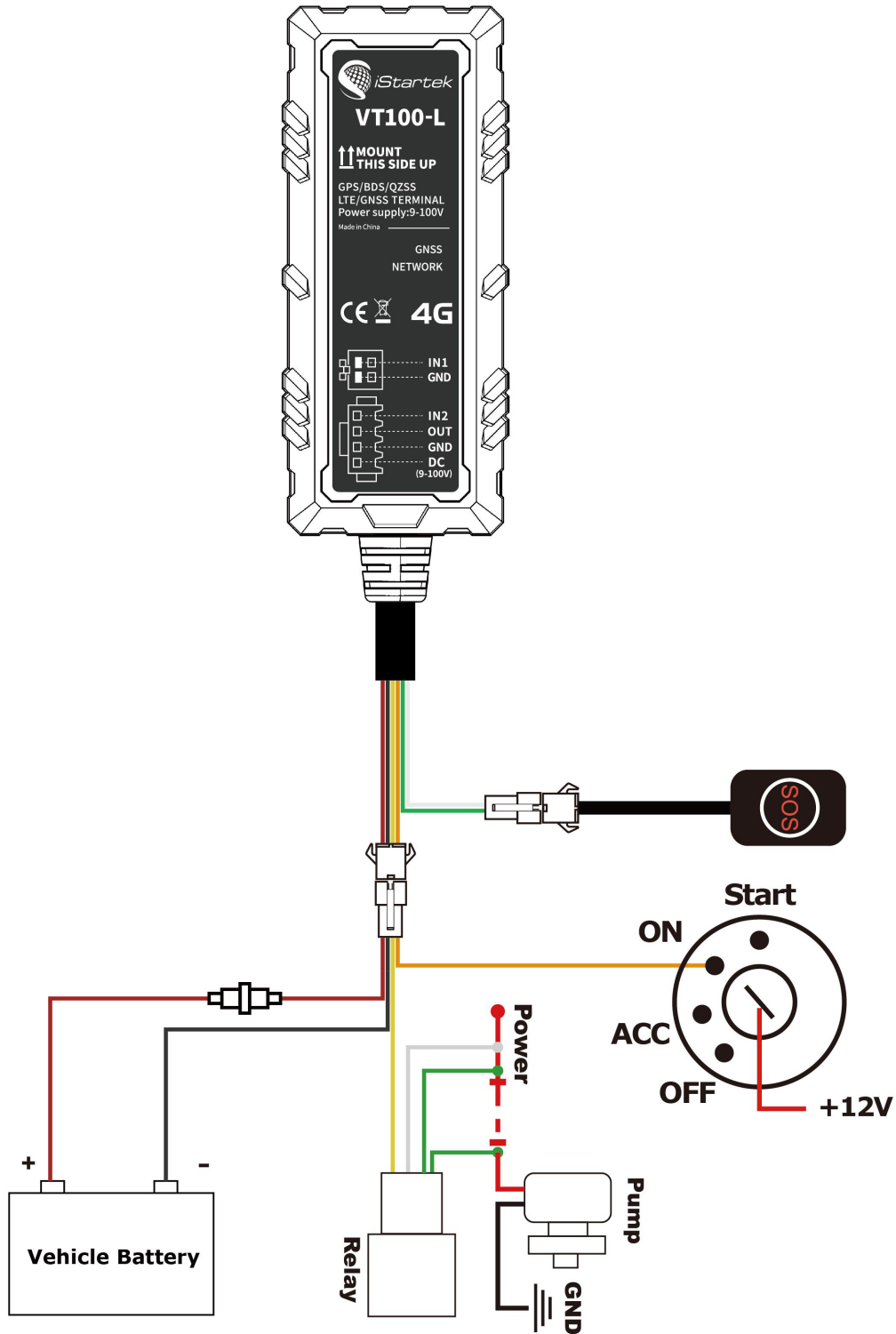

8.3 Analog Input Installation

The range of analog input AD1 and AD2 is 0-6.6V. Need to configure IN1 (white wire or IN2 (orange wire as AD INPUT, up to two fuel sensors (voltage output type sensors) can be connected, the wiring connection is as follows

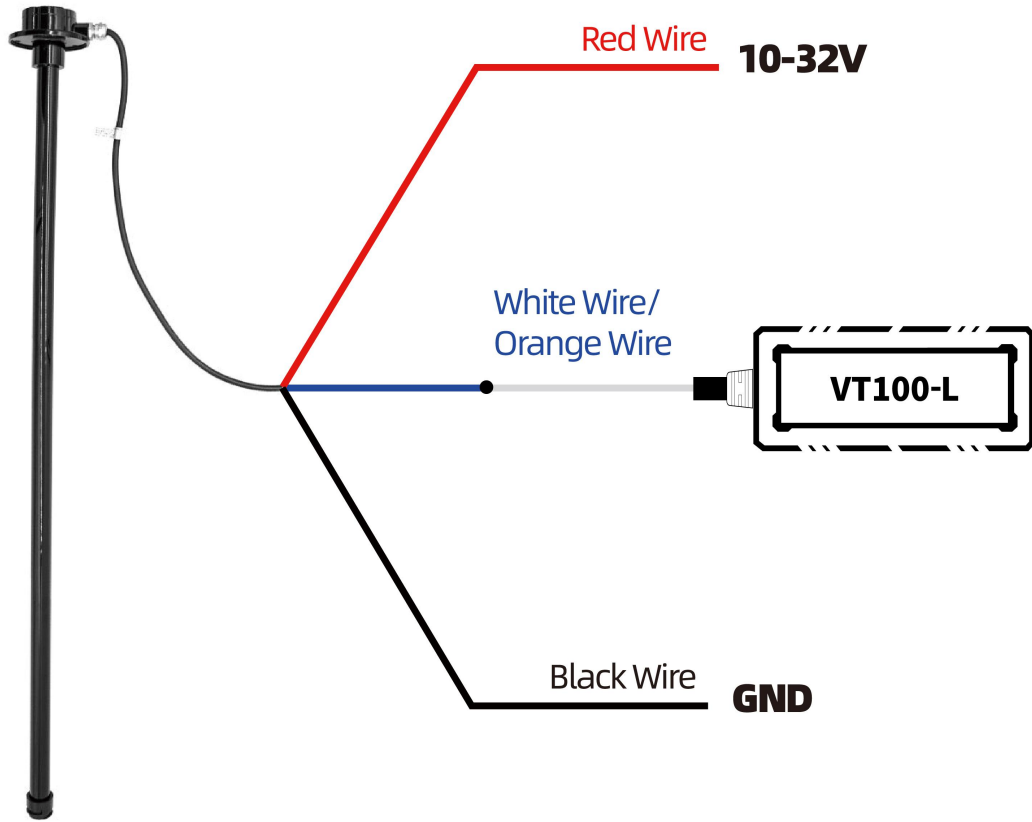

After connected wires, can set the size of the fuel tank (length, width, height), data source (AD1/AD2), sensor type (capacitive fuel sensor or ultrasonic fuel sensor), liters of fuel stolen, fuel stolen time, low fuel alarm by Parameter Editor.

The screenshot shows the configuration interface for the VT100-L device. The 'Interface' tab is selected. The 'Tank1' section is highlighted with a red box. It contains the following settings:

- Name: Right
- Source: AD1
- Sensor Type: Stick
- Length: 1000 mm
- Wide: 500 mm
- High: 1000 mm
- Steal: 20 Liter
- Steal Time: 60 s
- Low Fuel: 10 Liter

Other sections include:

- Input Mode:** Input1(AD1) Low Active, Active Time 0 ms; Input2(AD2) High Active, Active Time 0 ms.
- Out1 Mode:** Mode Open, Active Time 0 s, On Time 0 ms, Off Time 0 ms, Speed 0 km/h.
- Out2 Mode:** Mode Open, Active Time 0 s, On Time 0 ms, Off Time 0 ms, Speed 0 km/h.
- Serial Port:** RS232-1 None, RS232-2 None.

Buttons for 'Read' and 'Write' are located at the bottom of the interface.

For example, as above parameters setting, if the fuel tank connected to AD1 decreases more than 20 liters within 60 seconds, an fuel theft alarm will be generated; and if the fuel volume is less than 10 liters, a low fuel alarm will be generated.

Example: The fuel tank height is 100cm and full fuel is 50 liters, GPRS data as below:

```
&&A147,021104023195429,000,0,,180106093046,A,22.646430,114.065730,8,0.9,54,86,76,326781,460|0|27B3|0EA
7,27,0000000F,02,01,04E2|018C|01C8|0000,1,0104B0,01013D|02813546\r\n
```

AD1 voltage is **0x01C8** (hexadecimal=456 (decimal, **AD1=456/100** (fixed value=4.56V;

AD2 voltage is **0x0000=0, AD2=0/100=0V**;

Example: Connect the GPS Tracker analog input to capacitive fuel sensor, the yellow-green wire of the sensor are connected to the white wires (AD of the VT100-L.

When the fuel is empty, the sensor output voltage is 0V, when the fuel is full, the sensor output voltage is 5V

Calculate the percentage of remaining fuel:

Fuel percentage=(AD/5)*100%=(4.56/5)*100%=91.2%.

Calculate the remaining fuel in liters:

The remaining fuel in liters = **(AD/5) * 50 liters = 45.6 liters**

File Name	VT100-L User Manual	Ver.	1.0
Update	2022-02-28	Page	16 of 23

8.4 Ultrasonic Fuel Sensor Installation

8.4.1 Connect ultrasonic fuel sensor to VT100-L AD

Take the analog input of VT100-L connected to the fuel sensor as an example, the green wire of the sensor is connected to the IN1 white wire of VT100-L (Need to configure IN1 as AD1 by parameter editor) or the IN2 orange wire (Need to configure IN2 as AD2 by parameter editor)

① The height measurement range of the ultrasonic fuel sensor is 0~100cm (0-250cm optional) , and the corresponding voltage output range is 0~5V.

If the height of the fuel tank is H_0 cm and the fuel tank is full of F liters, the fuel sensor output voltage is $V=H_0/50$ when the fuel is full.

Calculate the remaining fuel volume:

Percentage of fuel = $(AD/V)*100\%$

The fuel volume height is: $H=(AD/5)*100$ cm

The remaining liters of fuel volume = $(AD/V)*F$ liters

② The height measurement range of the ultrasonic fuel sensor is 0~250cm , and the corresponding voltage output range is 0~5V.

Example: When the fuel is empty, the sensor output voltage is 0V. With a fuel tank height of 250cm as the standard, then fuel sensor output voltage is 5V when fuel is full.

If the height of the fuel tank is H_0 cm and the fuel tank is full of F liters, the fuel sensor output voltage is $V=H_0/50$ when the fuel is full.

Calculate the remaining fuel volume:

Percentage of fuel = $(AD/V)*100\%$

The fuel volume height is: $H=(AD/5)*250$ cm

The remaining liters of fuel volume = $(AD/V)*F$ liters

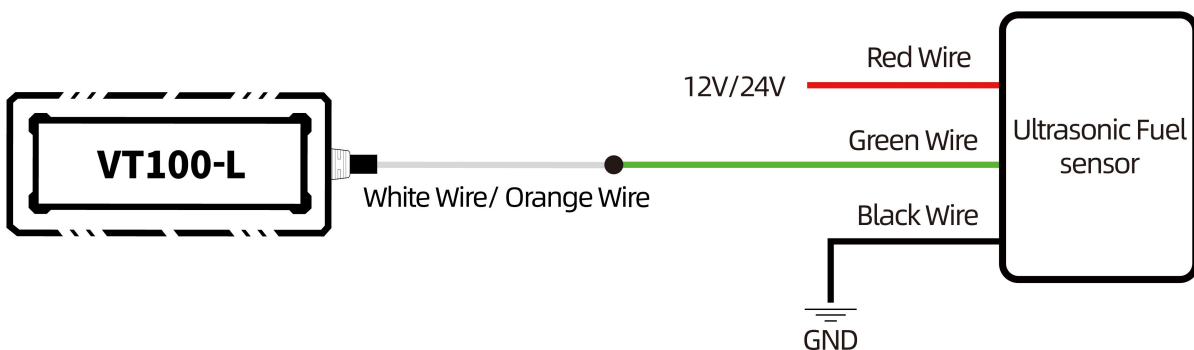

File Name	VT100-L User Manual	Ver.	1.0
Update	2022-02-28	Page	17 of 23

Example: The range of ultrasonic fuel sensor is 0-100cm, the height of the fuel tank is 100cm, and full oil is 50 liters:

00000000F,02,01,04E2|018C|00BA|0000,1,0104B0, 46\r\n

The voltage value of the AD1 is 0x00BA (hexadecimal)=186 (decimal), AD1=186/100 (fixed value)=1.86V;

The voltage value of AD2 is 0x0000=0, AD2=0/100=0V;

The output voltage when the fuel is full = $H_0/50=100/50=2V$

Percentage of remaining fuel= $(AD1/2)*100\%=(1.86/2)*100\%=93\%$

Height of remaining fuel volume: $H=(AD1/5)*250cm=(1.86/5)*250cm =93 cm$

The remaining fuel volume in liters = $(AD1/2) * 50 \text{ liters} = 45.6 \text{ liters}$

8.4.2 Connect ultrasonic fuel sensor to VT100-L RS232

Note: need hardware customization, the software version is only supported in V113 standard version and above

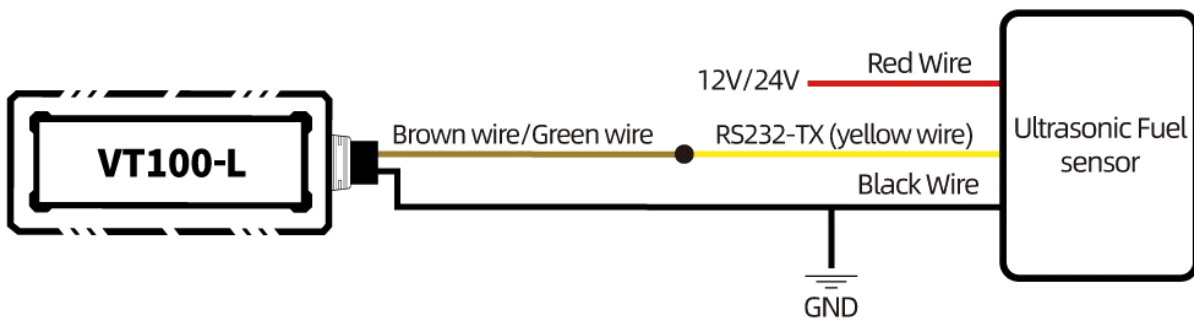

After connecting the wires and powering on, set the parameters:

8.4.2.1 Set parameters through parameter configuration software or SMS commands:

①. Configuration by Parameter Editor:

Select "Ultrasonic Sensor" and set the data source of the fuel tank (select RS232-1/2), the sensor type is ultrasonic fuel sensor (Ultrasonic(100cm)/(250cm)), the size of the fuel tank (length, width, height) these parameters, then the tracker can obtain the remaining oil value

File Name	VT100-L User Manual	Ver.	1.0
Update	2022-02-28	Page	18 of 23

The screenshot shows a configuration window with the following sections:

- Input Mode:** Input1(AD1) is set to 'Low Active' with an Active Time of 0 ms. Input2(AD2) is set to 'High Active' with an Active Time of 0 ms.
- Out1 Mode:** Mode is 'Open', Active Time is 0 s, On Time is 0 ms, Off Time is 0 ms, and Speed is 0 km/h.
- Out2 Mode:** Mode is 'Pulse', Active Time is 0 s, On Time is 100 ms, Off Time is 500 ms, and Speed is 0 km/h.
- Tank1:** Name is 'Right', Source is 'RS232-1', Length is 180 mm, Wide is 180 mm, High is 200 mm, and Sensor Type is 'Ultrasonic(250cm)'. Steal, Steal Time, and Low Fuel are all set to 0.
- Tank2:** Name is empty, Source is 'AD2', Length, Wide, and High are all 0 mm, and Sensor Type is 'No Sensor'. Steal, Steal Time, and Low Fuel are all set to 0.
- Serial Port:** RS232-1 is set to 'Ultrasonic Sensor' and RS232-2 is set to 'None'.

Buttons for 'Read' and 'Write' are located at the bottom of the configuration window.

② Configuration by SMS command:

Set by SMS command 138, 139, 142, 252

Send SMS commands according to the parameters set in the above figure,

Set fuel tank parameters, can send commands: 0000, 138, 1, 180, 180, 200

1 is the serial number of the fuel tank, the length of the fuel tank is 180mm, the width is 180mm, and the height is 200mm.

Set the fuel sensor type, you can send the command: 0000,139,1,3,Right Tank

"1" is the serial number of the fuel tank, "3" is the ultrasonic fuel sensor 250cm, and Right Tank is the name of the fuel tank.

Set the data source of the fuel tank, can send 0000,142,1,2

Set the data source of the 1# fuel tank to be RS232-1

Set serial port to connect with external device, send: 0000,252,1,4

Set 1# RS232 Ultrasonic fuel sensor

8.4.2.2 Set the baud rate of the ultrasonic fuel sensor

After opening the APP of the ultrasonic fuel sensor and connecting the Bluetooth, click "Settings", then enter the password "52381", click "Read" first - modify the baud rate as "115200" - click "Modify" - power off and restart ultrasonic fuel sensor.

File Name	VT100-L User Manual	Ver.	1.0
Update	2022-02-28	Page	19 of 23

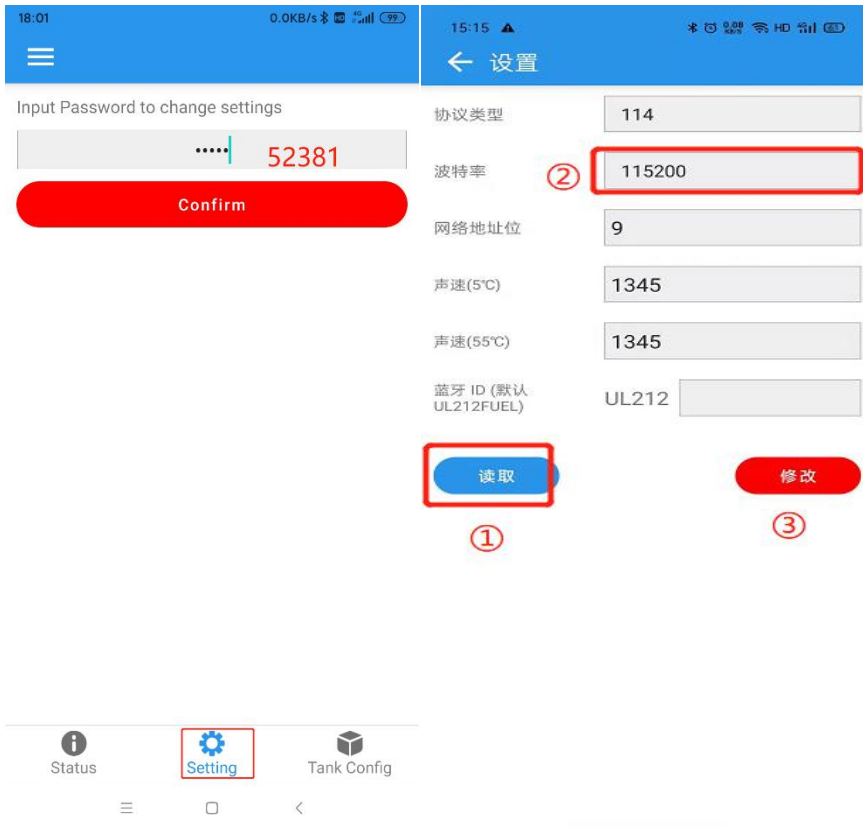

If the remaining fuel volume read by the tracker is L0 liters, the full fuel is F liters, and the fuel tank height is Hcm, the percentage and height of remaining fuel volume can be calculated:

Percentage of remaining fuel = $(L0/F)*100\%$

The height of remaining oil is: $H0 = (L0/F)*H$

Take the fuel tank height of 200cm and full fuel of 60 liters as an example of GPRS data:

```
&&k147,860262050015374,000,0,,210814070734,A,22.678986,114.046146,12,0.9,0,279,13,65,460|1|2609|061E278
3,31,0000003F,00,00,049 ,01001F,,D6\r\n
```

01001F: 01# fuel tank; 0x001F, the decimal value is 31, and the remaining fuel volume is 31/10=3.1 liters

Percentage of remaining oil = $(L0/F)*100\% = (3.1/60)*100\% = 5.17\%$

Height of remaining oil volume: $H0 = (L0/F)*H = (3.1/60)*200\text{cm} = 10.4 \text{ cm}$

8.4.2 Set fuel theft alarm and low fuel alarm

After connected wires, can set the size of the fuel tank (length, width, height), sensor type (capacitive fuel sensor or ultrasonic fuel sensor), fuel theft time, low fuel alarm by Parameter Editor.

- 1) **Configuration by Parameter Editor:** Set the fuel tank name to Right Tank; The data source of the fuel tank is AD1, Fuel tank type is ultrasonic fuel sensor; Fuel tank size, 1000mm in length, 500mm in width, and 1000mm in height; Set the fuel theft alarm to active when the fuel reduction exceeds 20 liters within 60 seconds; Set low fuel alarm to active when the fuel volume is less than 10 liters.

File Edit Help

Info | GPRS | Main | Interface | RFID | Temp | Auth | GEO | Event

Input Mode

Input1(AD1) Low Active Active Time ms

Input2(AD2) High Active Active Time ms

Out1 Mode

Mode Open

Active Time s

On Time ms

Off Time ms

Speed km/h

Tank1

Name Sensor Type Ultrasonic(250cm)

Source AD1

Length mm Steal Liter

Wide mm Steal Time s

High mm Low Fuel Liter

Tank2

Name Sensor Type No Sensor

Source AD2

Length mm Steal Liter

Wide mm Steal Time s

High mm Low Fuel Liter

- 2) **Configuration by SMS Command:** Set fuel tank parameters through SMS commands **138, 139, 140, and 141, 142**. For related parameter setting commands, please refer to "Pictor Telematics GPS tracker Communication Protocol V1.3".

Send above parameters by SMS commands:

Set fuel tank parameters, you can send commands: **0000,138,1,1000,500,1000**

Description: 1 is the serial number of the fuel tank. The length of the fuel tank is 1000mm, the width is 500mm, and the height is 1000mm.

Set the type of fuel sensor, you can send commands: **0000,139,1,1,Right Tank**

Description: The first "1" is for the serial number of the fuel tank, the second "1" is AD1 connected to ultrasonic fuel sensor, and Right Tank is the name of the fuel tank.

Set the fuel theft alarm, you can send commands: **0000,140,1,20,60**

Description: Set AD1 as the corresponding fuel tank, and the fuel theft alarm will be triggered when the fuel reduction exceeds 20 liters within 60 seconds.

Set low fuel alarm, you can send commands: **0000,141,1,10**

Description: Set AD1 as the corresponding fuel tank, and a low fuel alarm will be triggered when the fuel volume is less than 10 liters.

Note: The default data source of the fuel tank is AD1, and the default data source of the 2# fuel tank is AD2

Note: The 138, 139, 140, 141, 142 commands must be used to set the fuel tank parameters to detect the alarm.

File Name	VT100-L User Manual	Ver.	1.0
Update	2022-02-28	Page	21 of 23

8.5 Speed Limiter Installation

A. When the car is ignition on and idling, use a multimeter to measure and record the voltage V_H of the gas pedal high-level signal line and the voltage value V_L of the low-level signal line, as shown in the figure below. (Note: The position and color of the gas pedal signal wire of different models may be different, subject to actual measurement)



B. Connect the A01 speed limiter to the vehicle power supply, and connect the yellow control wire to the ground wire, open the bottom cover of the speed limiter housing, and use a screwdriver to adjust the two variable resistors (clockwise to increase the voltage value, counterclockwise to decrease the voltage value) so that the output voltage of the green signal wire is equal to the voltage value V_H , and the output voltage of the grey signal wire is equal to the voltage value V_L



C. Cut off the gas pedal signal wire of the car, and connect the GPS Tracker VT100-L and speed limiter as shown in the figure below. (Note: The color of the gas pedal signal wire of different car models may be different. The following figure is only an example, and subject to the actual vehicle signal line)

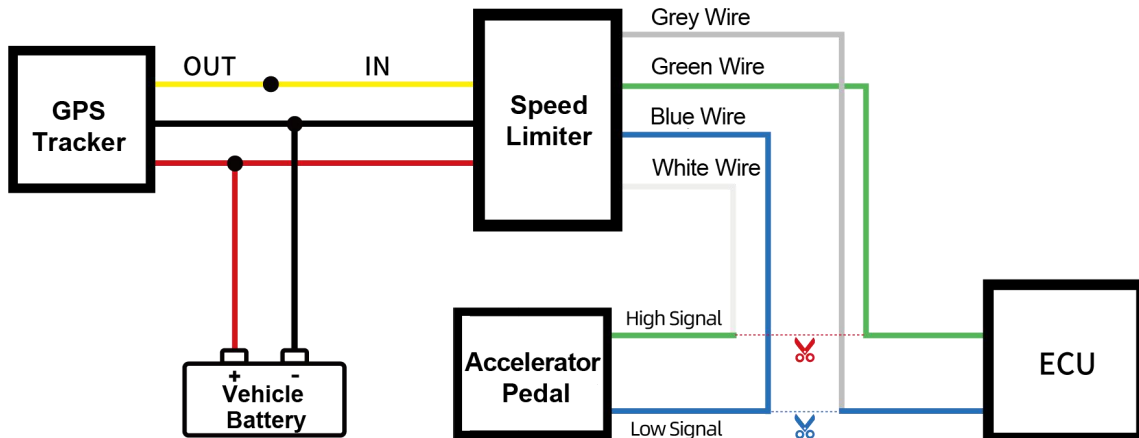

- ①. After the wires are connected, the speed limit value can be set through the parameter editor or SMS command:
- ②. Parameter editor settings: set as shown in the figure below:

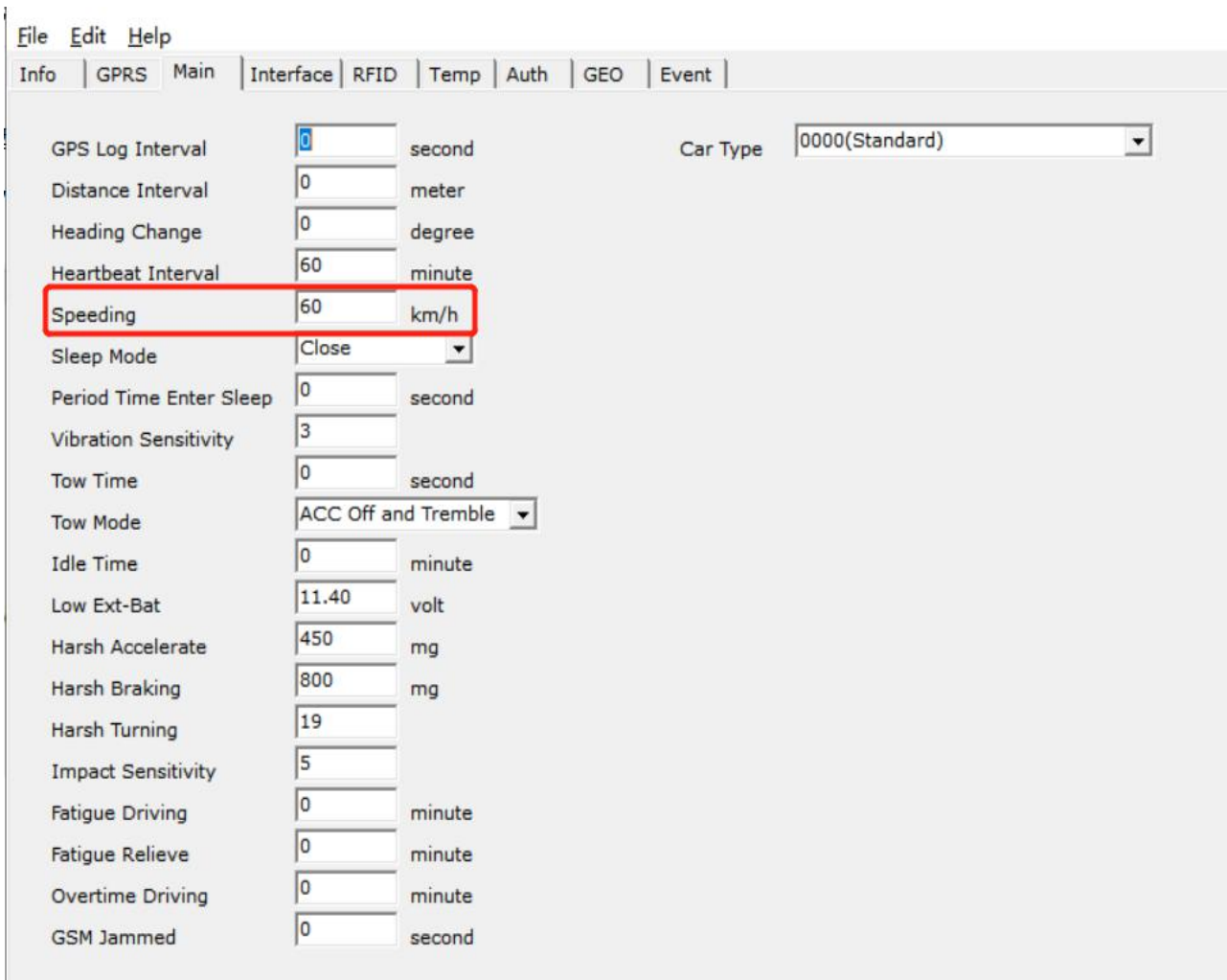

File Edit Help

Info GPRS Main Interface RFID Temp Auth GEO Event														
Event	SMS Alarm Name	GPRS		Auth No.1			Auth No.2			Auth No.3			Output	
		1	2	sms call moni	sms call moni	sms call moni	sms call moni	sms call moni	sms call moni	sms call moni	1	2		
(0) Interval tracking	Interval	<input checked="" type="checkbox"/>	<input checked="" type="checkbox"/>	<input type="checkbox"/>	<input type="checkbox"/>	<input type="checkbox"/>	<input type="checkbox"/>	<input type="checkbox"/>	<input type="checkbox"/>	<input type="checkbox"/>	<input type="checkbox"/>	<input type="checkbox"/>	<input type="checkbox"/>	
(1) Input1 active	SOS	<input checked="" type="checkbox"/>	<input checked="" type="checkbox"/>	<input type="checkbox"/>	<input type="checkbox"/>	<input type="checkbox"/>	<input type="checkbox"/>	<input type="checkbox"/>	<input type="checkbox"/>	<input type="checkbox"/>	<input type="checkbox"/>	<input type="checkbox"/>	<input type="checkbox"/>	
(2) Input1 inactive	In1 Inactive	<input type="checkbox"/>	<input type="checkbox"/>	<input type="checkbox"/>	<input type="checkbox"/>	<input type="checkbox"/>	<input type="checkbox"/>	<input type="checkbox"/>	<input type="checkbox"/>	<input type="checkbox"/>	<input type="checkbox"/>	<input type="checkbox"/>	<input type="checkbox"/>	
(3) Input2 active	Ignition On	<input checked="" type="checkbox"/>	<input checked="" type="checkbox"/>	<input type="checkbox"/>	<input type="checkbox"/>	<input type="checkbox"/>	<input type="checkbox"/>	<input type="checkbox"/>	<input type="checkbox"/>	<input type="checkbox"/>	<input type="checkbox"/>	<input type="checkbox"/>	<input type="checkbox"/>	
(4) Input2 inactive	Ignition Off	<input checked="" type="checkbox"/>	<input checked="" type="checkbox"/>	<input type="checkbox"/>	<input type="checkbox"/>	<input type="checkbox"/>	<input type="checkbox"/>	<input type="checkbox"/>	<input type="checkbox"/>	<input type="checkbox"/>	<input type="checkbox"/>	<input type="checkbox"/>	<input type="checkbox"/>	
(5) Input3 active	Door Open	<input checked="" type="checkbox"/>	<input checked="" type="checkbox"/>	<input type="checkbox"/>	<input type="checkbox"/>	<input type="checkbox"/>	<input type="checkbox"/>	<input type="checkbox"/>	<input type="checkbox"/>	<input type="checkbox"/>	<input type="checkbox"/>	<input type="checkbox"/>	<input type="checkbox"/>	
(6) Input3 inactive	Door Close	<input type="checkbox"/>	<input type="checkbox"/>	<input type="checkbox"/>	<input type="checkbox"/>	<input type="checkbox"/>	<input type="checkbox"/>	<input type="checkbox"/>	<input type="checkbox"/>	<input type="checkbox"/>	<input type="checkbox"/>	<input type="checkbox"/>	<input type="checkbox"/>	
(7) Input4 active	In4 Active	<input checked="" type="checkbox"/>	<input checked="" type="checkbox"/>	<input type="checkbox"/>	<input type="checkbox"/>	<input type="checkbox"/>	<input type="checkbox"/>	<input type="checkbox"/>	<input type="checkbox"/>	<input type="checkbox"/>	<input type="checkbox"/>	<input type="checkbox"/>	<input type="checkbox"/>	
(8) Input4 inactive	In4 Inactive	<input type="checkbox"/>	<input type="checkbox"/>	<input type="checkbox"/>	<input type="checkbox"/>	<input type="checkbox"/>	<input type="checkbox"/>	<input type="checkbox"/>	<input type="checkbox"/>	<input type="checkbox"/>	<input type="checkbox"/>	<input type="checkbox"/>	<input type="checkbox"/>	
(9) Input5 active	In5 Active	<input checked="" type="checkbox"/>	<input checked="" type="checkbox"/>	<input type="checkbox"/>	<input type="checkbox"/>	<input type="checkbox"/>	<input type="checkbox"/>	<input type="checkbox"/>	<input type="checkbox"/>	<input type="checkbox"/>	<input type="checkbox"/>	<input type="checkbox"/>	<input type="checkbox"/>	
(10) Input5 inactive	In5 Inactive	<input type="checkbox"/>	<input type="checkbox"/>	<input type="checkbox"/>	<input type="checkbox"/>	<input type="checkbox"/>	<input type="checkbox"/>	<input type="checkbox"/>	<input type="checkbox"/>	<input type="checkbox"/>	<input type="checkbox"/>	<input type="checkbox"/>	<input type="checkbox"/>	
(11) Input6 active	In6 Active	<input checked="" type="checkbox"/>	<input checked="" type="checkbox"/>	<input type="checkbox"/>	<input type="checkbox"/>	<input type="checkbox"/>	<input type="checkbox"/>	<input type="checkbox"/>	<input type="checkbox"/>	<input type="checkbox"/>	<input type="checkbox"/>	<input type="checkbox"/>	<input type="checkbox"/>	
(12) Input6 inactive	In6 Inactive	<input type="checkbox"/>	<input type="checkbox"/>	<input type="checkbox"/>	<input type="checkbox"/>	<input type="checkbox"/>	<input type="checkbox"/>	<input type="checkbox"/>	<input type="checkbox"/>	<input type="checkbox"/>	<input type="checkbox"/>	<input type="checkbox"/>	<input type="checkbox"/>	
(17) Ext-power low	Low Ext-Power	<input checked="" type="checkbox"/>	<input checked="" type="checkbox"/>	<input type="checkbox"/>	<input type="checkbox"/>	<input type="checkbox"/>	<input type="checkbox"/>	<input type="checkbox"/>	<input type="checkbox"/>	<input type="checkbox"/>	<input type="checkbox"/>	<input type="checkbox"/>	<input type="checkbox"/>	
(18) Ext-power lost	Ext-Power Cut	<input checked="" type="checkbox"/>	<input checked="" type="checkbox"/>	<input type="checkbox"/>	<input type="checkbox"/>	<input type="checkbox"/>	<input type="checkbox"/>	<input type="checkbox"/>	<input type="checkbox"/>	<input type="checkbox"/>	<input type="checkbox"/>	<input type="checkbox"/>	<input type="checkbox"/>	
(19) Ext-power connect	Ext-Power On	<input checked="" type="checkbox"/>	<input checked="" type="checkbox"/>	<input type="checkbox"/>	<input type="checkbox"/>	<input type="checkbox"/>	<input type="checkbox"/>	<input type="checkbox"/>	<input type="checkbox"/>	<input type="checkbox"/>	<input type="checkbox"/>	<input type="checkbox"/>	<input type="checkbox"/>	
(20) Internal battery low	Low Battery	<input checked="" type="checkbox"/>	<input checked="" type="checkbox"/>	<input type="checkbox"/>	<input type="checkbox"/>	<input type="checkbox"/>	<input type="checkbox"/>	<input type="checkbox"/>	<input type="checkbox"/>	<input type="checkbox"/>	<input type="checkbox"/>	<input type="checkbox"/>	<input type="checkbox"/>	
(21) GPS antenna cut	GPS Antenna Cut	<input checked="" type="checkbox"/>	<input checked="" type="checkbox"/>	<input type="checkbox"/>	<input type="checkbox"/>	<input type="checkbox"/>	<input type="checkbox"/>	<input type="checkbox"/>	<input type="checkbox"/>	<input type="checkbox"/>	<input type="checkbox"/>	<input type="checkbox"/>	<input type="checkbox"/>	
(22) Speeding alarm	Speeding	<input checked="" type="checkbox"/>	<input checked="" type="checkbox"/>	<input type="checkbox"/>	<input type="checkbox"/>	<input type="checkbox"/>	<input type="checkbox"/>	<input type="checkbox"/>	<input type="checkbox"/>	<input type="checkbox"/>	<input checked="" type="checkbox"/>	<input type="checkbox"/>	<input type="checkbox"/>	
(23) Enter sleep	Enter Sleep	<input checked="" type="checkbox"/>	<input checked="" type="checkbox"/>	<input type="checkbox"/>	<input type="checkbox"/>	<input type="checkbox"/>	<input type="checkbox"/>	<input type="checkbox"/>	<input type="checkbox"/>	<input type="checkbox"/>	<input type="checkbox"/>	<input type="checkbox"/>	<input type="checkbox"/>	

③. SMS command settings: send 123 commands and 212 commands, for example:

0000, 123, 60 Set the speed limit value to 60KM/H

0000,212,1,1,22 Set to trigger output 1 after exceeding the set speed value